

Foreward

Thank you for choosing COD_{uv}-6000 Turbidity Data Acquisition Terminal !

Please read this introduction carefully before installation, correct installation and parameter setting will use the performance and advantage of the product in the best way, bringing you a good using experience.

This instrument is a precision process analysis and control instrument, and it should be installed, operated and repaired by trained personnel or other personnel who understand and grasp this professional knowledge.

If you meet some difficulties in the process of the installation and using, please inquire Technical Support Department in time.

After unpacking, please be sure to check the complete set of list and the actual product you received, if there is anything missing or damaged, please contact in time.

The manufacturer promises seriously:

1. If quality problems appear within one year from the date of purchase, you will receive free product repair or replacement of a new instrument.
2. No matter in what way you get this product, manufacturer provides eternal technical maintenance as a promise for the sold instruments.
3. Damages to the product caused by the following reasons are not within the scope of the warranty:
 - a) Misconnection with high voltage power source or damage caused by flooding;
 - b) Damage caused by privately refitting and improper use;
 - c) Collateral damage because of the improper selection of model;
 - d) Damage caused by going beyond the using conditions of the product;
 - e) All physical damage caused by the improper pressure;
 - f) Failure appears because storage and transportation are not in accordance with the stipulations of storage or transportation conditions (reference standard SJ/T10463-93);
 - g) Consumable materials need to purchase separately.



When this symbol appears in the manual, it means that something about safety, installation, product function and using should be paid special attention!

Keep pace with the times is the rule of the enterprise development, there will be periodical upgrade of products, and we will not have further notice on general changes, please in kind prevail.

Content

I、 General Introduction	1
II、 Product Naming Standard.....	1
III、 Characteristics.....	1
IV、 Applications.....	2
V、 Main Features.....	4
VI、 Dimension and wiring connection.....	5
VII、 Installation and maintenance instructions.....	7
VIII、 Daily maintenance and precautions of the sensor.....	12
IX、 Product completeness.....	13
(1) Standard package.....	13
(2) Communication conversion accessories (optional)	13
(3) Display unit (optional)	15
(4) Product Installation accessories (optional)	15
(5) calibration accessories (optional)	16
Appendix 1: RS485-Modbus.....	16

I、General Introduction

The COD_{UV}-6000 data collection terminal is an online detection instrument that uses optical methods to detect COD content in water quality. The detection process does not require chemical reagents, obtains data quickly, and has no secondary pollution, so it is more environmentally friendly and has good application prospects.



The instrument is embedded with an intelligent core of measurement and calculation, and directly outputs the COD value through RS485 digital signal. It can also convert RS485 digital signal into RS232, 4-20mA, 4G, GPRS, Zigbee, LORA and other data formats through the data conversion module.

II、Product Naming Standard

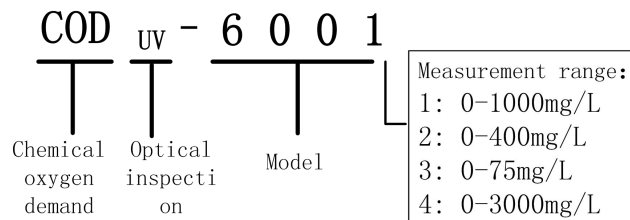

III、Characteristics

- Using ultraviolet optical method to test water quality COD parameters, without sample pretreatment; Fast detection and analysis, and no secondary pollution;

- Support parameter conversion, which can be converted into BOD, TOC, SAC254 and other parameters;
- Increasing the reference optical channel so that can effectively eliminate the interference of water turbidity to ensure the accuracy of the test;
- Using xenon light source, long life and high stability of continuous operation;
- Sensor type, with a small appearance, convenient installation and convenient carrying;
- Multi-optical path options are available, which can be adapted to the needs of different ranges in different occasions;
- Real-time detection, with the meaning of online detection, low maintenance frequency;
- Easy to maintain, the sensor is equipped with compressed air cleaning function, suitable for complex waters and easy to maintain;

IV、Applications

- ✧ Directly used as the data acquisition terminal of DCS and PLC system in the industrial field;
- ✧ Direct access to the cloud communication and big data platform through the DTU of the GPRS system;
- ✧ Directly use the WiFi module as a nearby wireless data collection terminal;
- ✧ Can use ZigBee/Lora module to remote wireless collection terminal;
- ✧ It can realize optical remote data collection through optical transceiver and far-infrared terminal;
- ✧ Supporting traditional 4-20mA industrial system (cable end RS485/4-20mA) module conversion;

- ✧ With a variety of 485/WiFi/USB tool converter, you can achieve calibration, address search, baud rate search and configuration by APP.



Diagram 4.1 Different display mode of data acquisition terminal

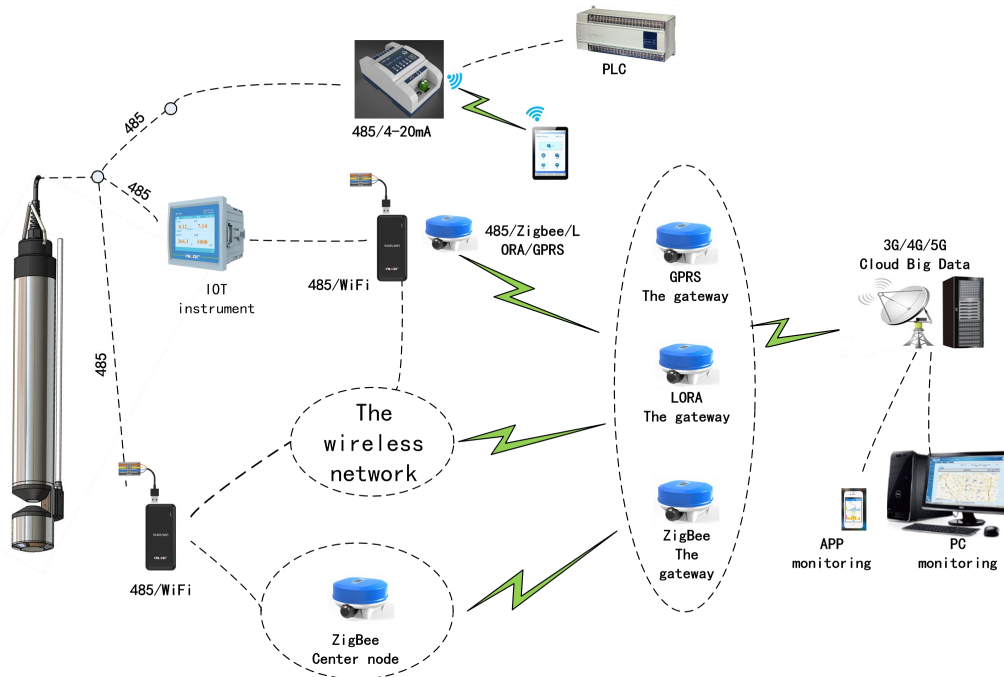

4.2 Connection diagram

V、Technical index

Product Name	COD _{UV} -6000 Data Acquisition Terminal			
Model	COD _{UV} -6001	COD _{UV} -6002	COD _{UV} -6003	COD _{UV} -6004
Measurement range	0-1000mg/L	0-400mg/L	0-75mg/L	0-3000mg/L
Accuracy (based on KHP)	Less than $\pm 5\%$ of reading or 2mg/L	Less than $\pm 5\%$ of reading or 1mg/L	Less than $\pm 5\%$ of reading or 0.5mg/L	Less than $\pm 5\%$ of reading or 5mg/L
Repeatability	$\pm 5\%$ of reading			
Working environment	Temperature: (0~45) °C ; Humidity: $\leq 95\%$ RH(none considation)			
Pressure	0.4Mpa			
Storage environment	Temperature: (-10~60) °C ; Humidity: $\leq 95\%$ RH(none considation)			
Cable length	Standard 10m (out of factory) ; support (1~300) m (book)			
Communication	RS485 communication Modbus-RTUstandard protocol			
Power supply	DC (9-28) V			
Power	<5W			
Weight	1.5Kg			
Protection level	IP68			

Note: The data acquisition terminal is based on KHP (potassium hydrogen phthalate solution) for calibration detection. Many impurities on site have different absorption characteristics than KHP, so on-site calibration is recommended.

VI、 Dimension and wiring connection

① Product size

1. Whole size

The complete COD data collection terminal is composed of the collection part and the air blowing cleaning module. The length and size of the data collection terminal are different when the optical path is different.

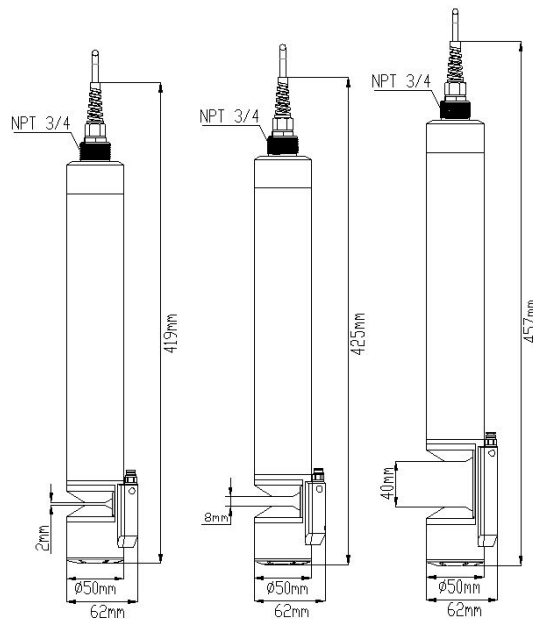

Diagram 6.1 Product effect and dimensions

② Wiring Connection

1. Sensor Cable

In order to obtain longer distance transmission and environmental tolerance, the cross-sectional area of the power cord used in this data acquisition terminal is slightly larger. Therefore, it is not recommended that customers replace other specifications of

commercial cables in order to avoid affecting transmission characteristics. It is recommended to reserve a relatively rich length or original factory cable when purchasing products.

2. Transmission Distance

Data acquisition terminals with different attributes have different maximum limits, and the length supported by different supply voltages is different. Please calculate the maximum distribution distance according to the table below.

Input voltage	Loop current	Maximum loop resistance	Maximum length of cable
24V	250mA	60 Ω	300m
12V	150mA	20 Ω	100m

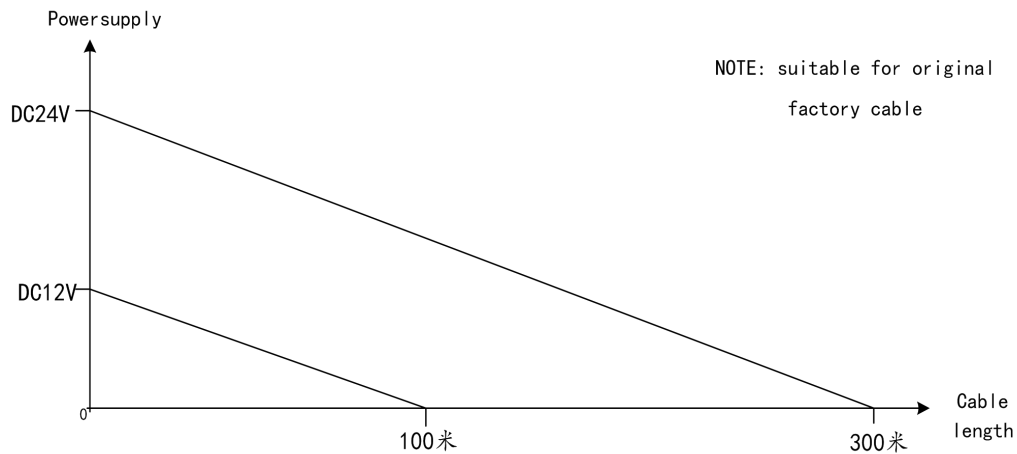

Diagram 6.2 of power supply and cable length



Diagram 6.3 of wiring connection

③ Communication Setting

1. Address and speed: Default baud rate: 9600;Mailing address: 01
2. Batch setting, Factory provides product calibration and hand operator for batch setting, you can be set through the APP; If you have already set the address and speed, you can find the current address and redefine the new address and speed in the APP.
3. To use the hand operator, connect the four wires at the end of the cable to the hand operator, scan the QR code on the hand operator, download a program from the cloud, and turn on the hand operator to complete address modification or product calibration and other work.
4. Offline setup and operation

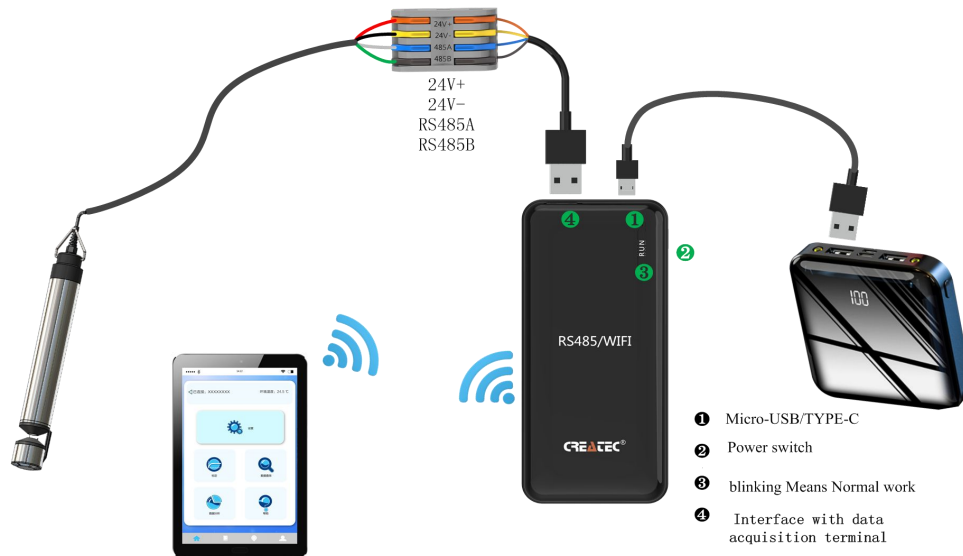

Diagram 6.4 Offline setting diagram

VII、Installation and maintenance instructions

① Installation Method

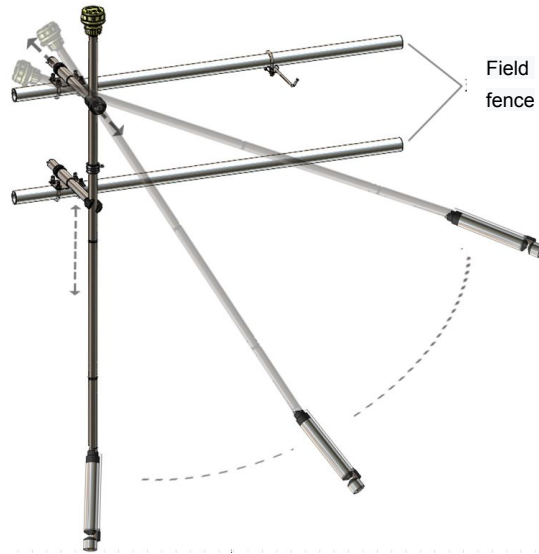

Diagram 7.1 Environmental protection bracket installation

1. Environmental protection bracket installation

It is universally applicable to the support and installation of collection terminals of environmentally friendly sewage treatment plants and other pools or open channels and aquaculture ponds. It is convenient for on-site maintenance. It is an innovative installation method that is safe, convenient, compatible, hygienic and civilized.

When there are many impurities in the water body and the lens of the sensor window is easy to accumulate, you can also purchase our company's automatic air blowing maintenance device to automatically perform air blowing cleaning operations at regular intervals to eliminate these effects.

2. Wireless remote connection

In construction sites that are blocked by rivers, ponds, and buildings, where bridges, pipes, and wiring cannot be erected, you can purchase our company's LORA or Zigbee or WIFI wireless modules to achieve remote wireless transmission. This is favored by user engineers in scenarios such as environmental monitoring, sewage treatment plants, aquaculture farms, and subsequent expansion of factories because of the convenience of networking.

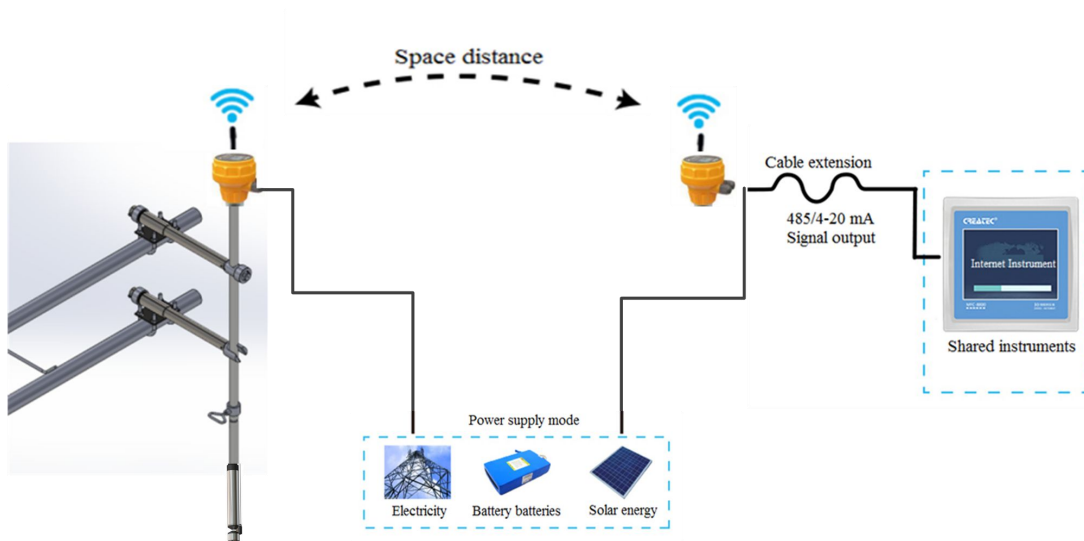

Figure 7.2 Schematic diagram of wireless remote connection

Note: WiFi-short-range communication only under barrier-free barriers;
 LORA—Long-distance (about 10Km) communication without obstacles;
 Zigbee-when encountering obstacles, it is composed of multiple relay relays to avoid obstacles.

3.



Diagram 7.3 Field data bus serial application

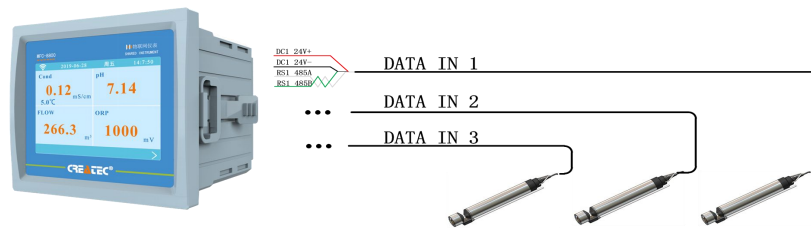

Diagram 7.4 Field data parallel application

In the industrial site, the original cable is used to meet a variety of serial power distribution, reducing on-site construction and maintenance costs.

② Calibration of data collection terminal

1. Calibration preparation

The COD_{uv}-6000 high turbidity data acquisition terminal has been calibrated when it leaves the factory. If you need on-site inspection or verify whether it is accurate after a period of use, you can calibrate the collection terminal. The instrument has three calibration methods:

1. This data acquisition terminal (without its own display instrument) directly outputs RS485 digital signals, The digital interface can be directly matched to display with industrial computer, configuration display, PLC, RS485 communication port instrument, and use our company's digital upper computer software setting on the man-machine interface of the above equipment And calibration software to set up and calibrate the instrument.
2. It can also be connected to the computer through the RS485/RS232 or USB port converter, and the upper computer software is installed to complete the calibration and calibration of the instrument.

The upper computer calibration software can be registered and obtained by logging in to our company's website.

3. You can use the company's data collection terminal handheld operator to complete the setting operation under the APP, and the APP scans the QR code on the handheld operator to download the application applet;

Scan the QR code on the product to download the calibration program, and complete the calibration check and other corresponding settings

according to the operation steps in the APP interface.

2. Calibration Operation

The chemical oxygen demand calibration requires the use of COD standard solution to calibrate the instrument; when customer site conditions permit, it is recommended to use deionized water for zero-point calibration of the instrument.

When the instrument needs slope calibration, you can consult our company in advance to order the required COD standard solution;

If the customer site or laboratory has the conditions and ability to prepare the turbidity standard solution, you can configure the COD standard solution by yourself according to the following methods.

The configuration method of COD standard solution is as follows:

Prepare potassium hydrogen phthalate standard solution according to national GB11914-89 (or environmental protection industry standard HJ/T 399-2007): Take appropriate amount of potassium hydrogen phthalate and place it in a drying oven, set the temperature to 105° C and dry for 2 hours . Dissolve 0.4251 g of dried potassium hydrogen phthalate in pure water, transfer to a 1000 mL volumetric flask, dilute to the mark, and shake well. The theoretical COD value of the prepared stock solution is 500mg/L. Solutions of other concentrations are then diluted with standard solutions.

Model	Optical path	Recommended calibration point
COD _{uv} -6003	40mm	45mg/L
COD _{uv} -6002	8mm	250mg/L
COD _{uv} -6001	2mm	600mg/L

COD _{uv} -6004	1mm	1500mg/L
-------------------------	-----	----------

Slope calibration: clean the calibration cylinder twice with deionized water and wipe dry; pour a small amount of standard solution into the calibration cylinder and rinse again; slowly (to avoid bubbles) pour the standard solution in the bottle into the calibration cylinder (guarantee solution The height of the surface is about 15cm); immediately put the probe into the calibration cylinder; the window of the probe should be about (2-3) cm (1 inch) below the water surface; wait for the measured value of the data acquisition terminal to stabilize, click the slope calibration to set the standard Input the COD value of the liquid, and calibrate the COD calculation slope of the collection terminal;

VIII、Daily maintenance and precautions of the sensor

Maintenance

- 1) It is recommended to clean the measuring end of the sensor regularly according to the media conditions on site, and to calibrate the meter regularly;
- 2) The measuring window is made of optical quartz glass. When maintaining, you can choose to immerse and clean it with a neutral detergent. After it is cleaned with pure water, use an eye cloth or lens test paper to clean it. Pay special attention to the damage of the measurement window which will directly lead to the damage of accuracy. Maintain the device to avoid scratching the surface with hard objects, which will affect the measurement accuracy.
- 3) For the site where the supporting air blowing device is installed, the air source air guide tube can be pulled out and cleaned, and then inserted into the quick connector. Put the



front of the sensor in clean water, open the air blowing cleaning operation for 5-10 minutes, and fully flush the air blowing pipeline.

IX、Product completeness

1) Standard package

Order number	Name	Model	Unit	Picture
248790	COD data acquisition terminal	COD _{UV} -6001	set	
248791	COD data acquisition terminal	COD _{UV} -6002	set	
248792	COD data acquisition terminal	COD _{UV} -6003	set	
248813	COD data acquisition terminal	COD _{UV} -6004	set	
	Operational Manual	COD _{UV} -6000	set	
	COD _{UV} -6000 Certification		set	

2) Communication conversion accessories (optional)

Order number	Name	Specification model	Unit	Picture
248764	RS485/4-20mA Conversion module	CEM-6232	set	 For integrated use inside the chassis
	RS485/RS232 converter	CEM-6120	set	





COD_{UV}-6000 Data Acquisition Terminal

	RS485/CAN converter	CEM-6251	set	
	RS485/Lora converter	CEM-6362	set	 For outdoor waterproof installation
	RS485/ZigBee converter	CEM-6372	set	
	RS485/ Optical converter	CEM-6280	set	For integrated use inside the chassis 
	RS485/Ethernet converter	CEM-6290	set	 For integrated use inside the chassis
	RS485/HART converter	CEM-62A0	set	 For integrated use inside the chassis
	RS485/ Infrared communication converter	CEM-62C0	set	 For integrated use inside the chassis
	modbus/profibus converter	CEM-62B0	set	 For integrated use

COD_{UV}-6000 Data Acquisition Terminal



				inside the chassis
248778	Hand-held Operator	RS485/WIFI CEM-6100	set	 Portable

3) Display unit (optional)

Order number	Name	Specification model	Unit	Picture
510054	Universal multi-function controller (Wall-mounted)	MCC-2300	set	
242010	Universal multi-channel controller (Panel type)	MFC-1380 (138*138)	set	
242009	Universal multi-channel controller (Sealed)	MFC-1200	set	
248769	IoT instrument	MFC-8800 (96*96)	set	

4) Product Installation accessories (optional)

Order	Name	Model	set	Picture
-------	------	-------	-----	---------

Number				
1051034	Environmental protection sensor bracket	ESB-100-PP-DN25	set	
	Air source automatic cleaning and maintenance		set	

5) Connector (optional)

Order number	Name	Specification model	Unit	Picture
112031814	Bus waterproof splitter	M20T-Tee-4 core	pc	

Appendix 1

Register number	symbol	Parameter	Address	Type	Value range	Remark
40001		Instrument model letter	0	Read only		30 stands for CODUV UV COD data collection terminal
40002		Instrument model number	1		0-65535	6000

COD_{UV}-6000 Data Acquisition Terminal

40003 40004		Measurement value	2 3		32-bit integer	COD Measurement value	
40005		COD Unit and decimal point	4		High eight decimal places Low eight unit	0x00xx: no decimal, 0x01xx: one digit 0x02xx: two digits, 0x03xx: three digits Refer to the attached table for unit representation	
40006 40007		Turbidity Measurement value	5 6		32-bit integer	Turbidity Measurement value	
40008		Turbidity Unit and decimal point	7		High eight decimal places Low eight unit	0x00xx: no decimal, 0x01xx: one digit 0x02xx: two digits, 0x03xx: three digits Refer to the attached table for unit representation	
40009- 40014		Reserved	8- 13				
40015		Temperature	14		16-bit integer	Temperature Measurement value	
40016		Temperature Unit and decimal point	15		High eight decimal places Low eight unit	Unit: °C, fixed to one decimal place.	
40017 40018		COD Measurement value	16 17		32-bit floating point		
40021		Task selection	20		Re ad and wr it e	16-bit integer	0: Main measurement 2: COD 3: Turbidity The user calibration process is shown in the attached picture
40023		Standard solution calibration result	22	16-bit integer		0: No calibration this time 1: Successful calibration 2: Calibration failed	
40024		Standard liquid actual value setting	23	16-bit integer 17-0-4000 0		Enter the actual value of COD and turbidity standard solution, the value range is 0-400, representing COD:	

COD_{UV}-6000 Data Acquisition Terminal

					0-400mg/L; turbidity: 0-400NTU. No decimal places. Then enter the start calibration mark after the standard solution measurement value stabilizes. Standard solution calibration is performed immediately after the instrument detects the start calibration mark The default is 200
40025- 40045		reserved	24- 44		
40046		COD Range display	45	16-bit integer	0 is the small range for COD measurement 1 for COD measurement with a large range
40050		Turbidity compensation selection mark	49	16-bit integer	0 means no turbidity compensation 1 means there is turbidity compensation, the default is 0
40056		COD measurement value migration	55	16-bit integer	Range: 0-200, no decimal places
40057		COD measurement value migration symbol	56	16-bit integer	1: +, 2:- Default is 1
40058		Restoration of appearance setting flag	57		The default is 0, 1 is to restore factory settings
40066		Xenon lamp flicker frequency adjustment	65	16-bit integer	The default is 1000, which means the light-on time is 1s, and the light-off time is 1s. After the change, it will take effect after the power is turned off and restarted.
40067		Xenon lamp's flicker light intensity voltage adjustment	66	16-bit integer	Value range: 0-4095 The default is: 3500
40072		Turbidity 1 measures AD value	71	16-bit integer	Channel 0 acquisition and measurement ad value

COD_{UV}-6000 Data Acquisition Terminal

40074		COD measurement small range AD value	73		16-bit integer	Channel 2 acquisition and measurement ad value
40075		COD measurement large range AD value	74		16-bit integer	Channel 3 acquisition and measurement ad value
40100		Baud rate	99	Re ad ab le W rit ab le	16-bit integer	1:1200,2:2400,3:4800, 4:9600 Default :4
40101		Adress	100		16-bit integer	1-247 Default :1

Unit function code Appendix

Read value	00	01	02	03	04	05	06	07
unit	无	μS/cm	mS/cm	MΩ·cm	mV	V	mg/L	g/L
Read value	08	09	0A	0B	0C	0D	0E	0F
unit	%	℃	℉	Hz	m/h	m ³ /s	m ³	m ³ /h
Read value	10	11	12	13	14	15	16	17
unit	ppm	ppt	m/s	L	mA	mbar	NTU	FNU
Read value	18	19	1A	1B	1C	1D	1E	1F
unit	s	GPM	Gal	Pluse/min	mm	%	pH (Non-unit)	h
Read value	0x28	29	2A	2B	2C	2D	2E	30
unit	g/L							